



Brock's Performance • 4064 E. Patterson Rd. • Dayton, OH 45430 • Phone: 937-912-0054 • Fax: 937-912-0062

Suzuki GSX-R1000 (09-11): Check F.I. Light Disconnect Instructions

When installing any Brock's Performance exhaust system on GSX-R1000 (09-11), the following procedure must be followed to prevent illumination of the check F.I. Light.

1. Disconnect the cables from the factory exhaust control valve actuator (EXCVA) located beneath the main side fairing on the left side of the bike. DO NOT unplug the EXCVA electrical connectors from the wiring harness. Do not remove the EXCVA unit.
2. Remove the OEM exhaust system, exhaust control valve and cables.
3. Install your Brock's Performance exhaust system according to the supplied instructions.
4. Remove the black connector (right side) from the ECM, the lock tab is on the bottom side and needs depressed to remove.
5. Locate the black wire with white tracer (with two green dots) on the black ECM connector. Viewing bottom of connector (side with lock tab), is 5th wire from right side. See Fig. 1.
6. Cut the wire approximately 1.5 inches back from the coupler and insulate both ends with electrical tape.

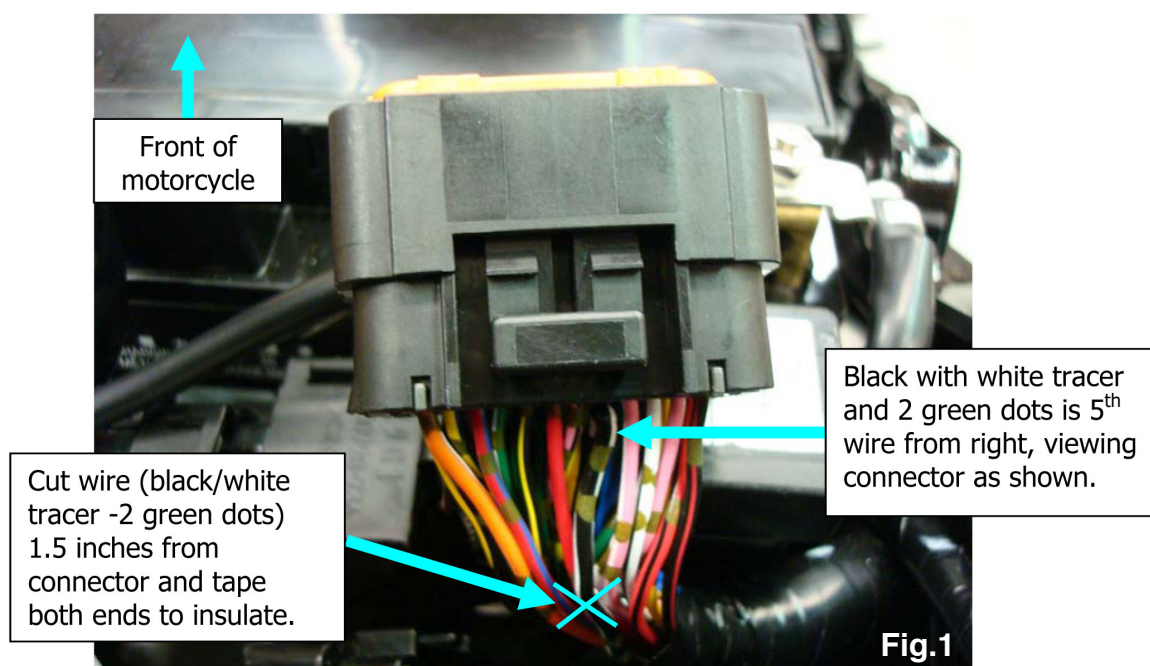

The motorcycle may now be operated in normal fashion without the check F.I. light illuminated.

All Brock's Performance products are designed for closed-course race track use ONLY!

For more information on Brock's Performance Warranty and Terms and Conditions:
www.BrocksPerformance.com > About Us > Terms and Conditions

For Questions and Comments:

www.BrocksPerformance.com > Customer Service > Contact Us, or call the Tech Line 937-912-0054