



Brock's Performance • 4064 E. Patterson Road • Dayton, OH 45430 • Phone: 937-912-0054 • Fax: 937-912-0062

SUZUKI GSX-R1000/R (17-18) BrockSTAND™ PRODUCT INFORMATION

The GSX-R1000/R BrockSTAND™ is designed to easily provide users with a full range of adjustability from 'ultra-slammed' drag to street applications using only a 4mm hex key.

Adjustment ranges: Road Version 0.00" to -2.00" / Track Version -2.00" to -4.00"

Package Contents:

GSX-R1000/R BrockSTAND™ shown:

1. One (1) Black Anodized Body
2. One (1) Black Anodized Foot
3. One (1) Adjustment Bolt
4. One (1) Spring Mounting Stud
5. One (1) Safety Switch Plate
6. Two (2) Safety Switch Plate Mounting Bolts
7. One (1) Blue Threadlocker 0.5ml (not shown)

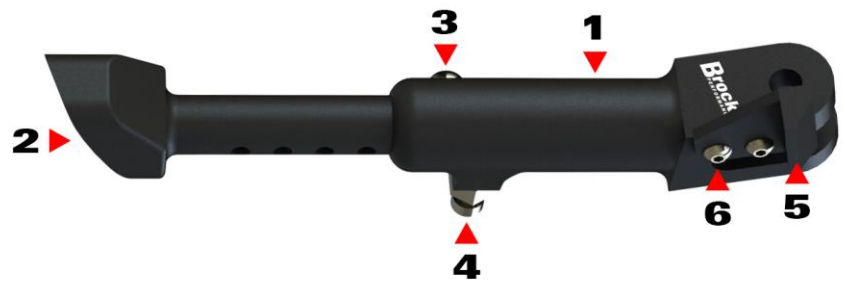

Installation Notes:

- Installs using the OEM kill switch, springs, and mounting hardware. See page 2 for side-stand installation and removal instructions from the OEM GSX-R1000/R service manual.
- When adjusting the foot length, it is recommended to apply blue threadlocker (supplied) to the threads of the Adjustment Bolt (3) before installation.
- Red threadlocker is applied to the Spring Mounting Stud (4) and Safety Switch Plate Mounting Bolts (6) during factory assembly. The Spring Mounting Stud (4) and Safety Switch Plate Mounting Bolts (6) should not be removed. In the event removal is required, apply red threadlocker to the threads before installation.
- **Installation Tip:** To ease spring removal/installation, fold the kickstand down to fully extend the spring. Place a penny between each of the open spring coils. When the kickstand is folded up, the spring will remain extended and be easier to remove/install.

ALL BROCK'S PERFORMANCE PRODUCTS ARE DESIGNED FOR CLOSED-COURSE RACETRACK USE ONLY!

For more information on Brock's Performance Warranty and Terms and Conditions:

BrocksPerformance.com > Brock's Support > Customer Service > Terms and Conditions

For Questions and Comments:

BrocksPerformance.com > Brock's Support > Customer Service > Contact Us or call 937-912-0054

Side-stand Removal and Installation

Removal

1) Support the motorcycle with a jack or wooden block.

⚠ CAUTION

- Do not support the motorcycle with the exhaust pipes.
- Make sure that the motorcycle is supported securely.

2) Remove the side-stand as shown in the side-stand construction. Refer to “Side-stand Construction”.

Installation

Install the side-stand as shown in the side-stand construction. Refer to “Side-stand Construction”.

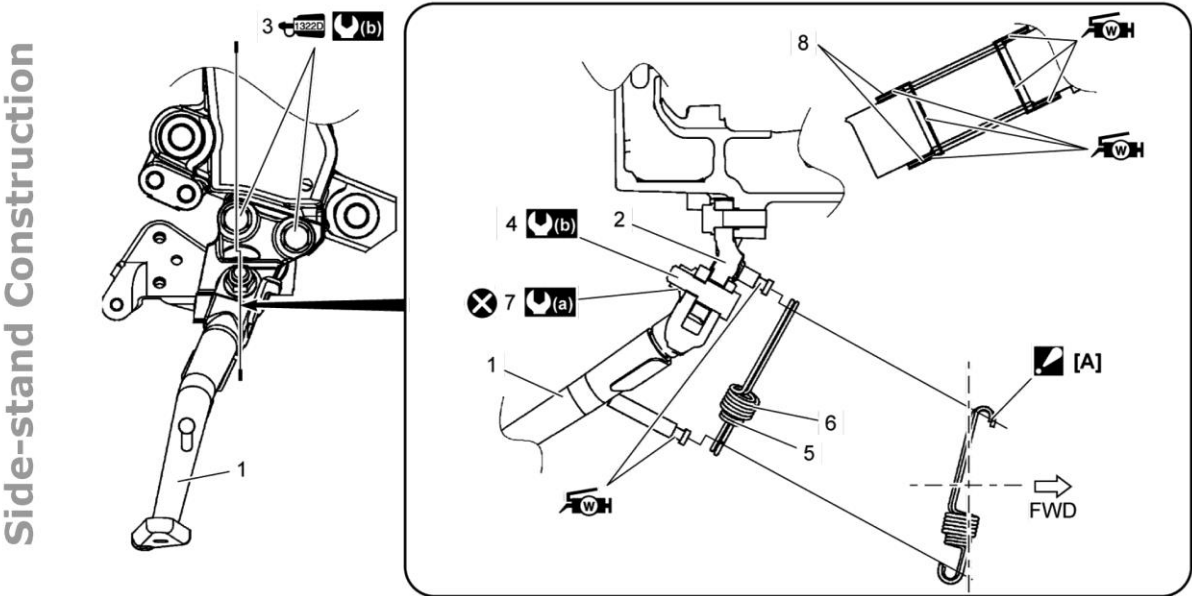

| | | |
|-------------------------------------|-----------------------------------|--|
| [A]: Take care of spring direction. | 5. Side-stand No. 1 spring | : 50 N·m (5.1 kgf-m, 37.0 lbf-ft) |
| 1. Side-stand | 6. Side-stand No. 2 spring | : Apply water resistant grease to the sliding surface. |
| 2. Side-stand bracket | 7. Side-stand nut | : Apply thread lock to the thread part. |
| 3. Side-stand bracket bolt | 8. Side-stand washer | : Do not reuse. |
| 4. Side-stand bolt | : 40 N·m (4.1 kgf-m, 29.5 lbf-ft) | |

ALL BROCK'S PERFORMANCE PRODUCTS ARE DESIGNED FOR CLOSED-COURSE RACETRACK USE ONLY!

For more information on Brock's Performance Warranty and Terms and Conditions:
BrocksPerformance.com > **Brock's Support** > **Customer Service** > **Terms and Conditions**

For Questions and Comments:
BrocksPerformance.com > **Brock's Support** > **Customer Service** > **Contact Us** or call **937-912-0054**