



Brock's Performance • 4064 E. Patterson Road • Dayton, OH 45430 • Phone: 937-912-0054 • Fax: 937-912-0062

GSX-R1000/R (17-23) CUSTOM PILOT SEAT INSTALLATION INSTRUCTIONS

The custom pilot seat is a direct bolt-on replacement seat for the Suzuki GSX-R1000. The seat features premium Comfort Cell® foam for less rider fatigue on long trips. A 'cut' section lowers the seat height providing the rider with more positive ground contact.

Package Contents:

The Package Contents Include:

1. One (1) Custom Pilot Seat

If your package contents differ, please contact Brock's Performance at 937-912-0054.

For additional installation support please refer to the OEM service manual.



Installation Notes:

1. Remove the frame front covers (Fig 1).
2. Remove the OEM front seat (Fig 2).
3. Install the custom pilot seat, sliding the seat hooks into the seat hook retainers on frame (Fig 3).

Note: The front mounting brackets are slotted for adjustment, adjust as needed to obtain proper alignment.

4. Reuse the OEM bolts and tighten securely to attach seat.
5. Reinstall the frame front covers (Fig 1).

Care Notes:

Vinyl is an extremely durable and weather-resistant product and therefore requires little care. It is suggested to avoid any cleaners and/or conditioners that are petroleum-based as they could lead to fading and eventual breakdown of the material. Cleaning can be achieved with [Corbin's Saddle Cream](#) or a similar product.

Note: The Comfort Cell® foam has a memory feature. It will take approximately 1500-2000 miles for the saddle to shape to the rider.

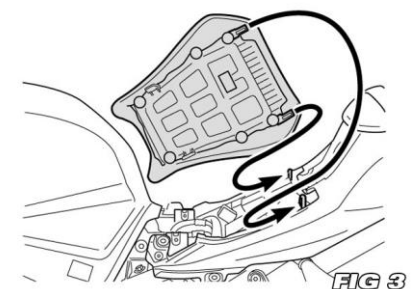
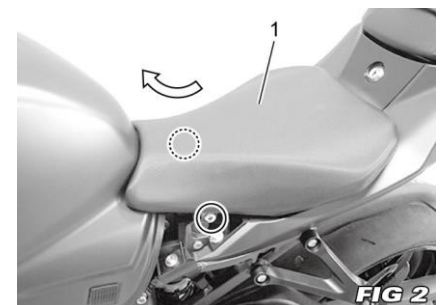
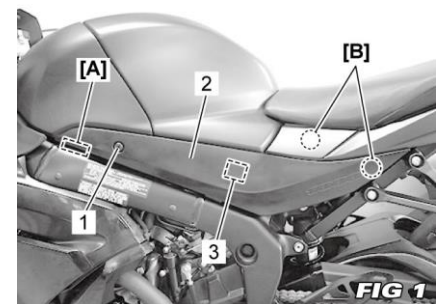

ALL BROCK'S PERFORMANCE PRODUCTS ARE DESIGNED FOR CLOSED-COURSE RACETRACK USE ONLY!

For more information on Brock's Performance Warranty and Terms and Conditions:

BrocksPerformance.com > Brock's Support > Customer Service > Terms and Conditions

For Questions and Comments:

BrocksPerformance.com > Brock's Support > Customer Service > Contact Us or call 937-912-0054