



YOSHIMURA

RESEARCH&DEVELOPMENT OF AMERICA, INC.

5420 DANIELS STREET STE A, CHINO CA., 91710 · (800)634-9166 · (909)628-4722 · FACSIMILE (909)591-2198

www.yoshimura-rd.com

FENDER ELIMINATOR KIT

070BG111820
Suzuki GSX-R1000

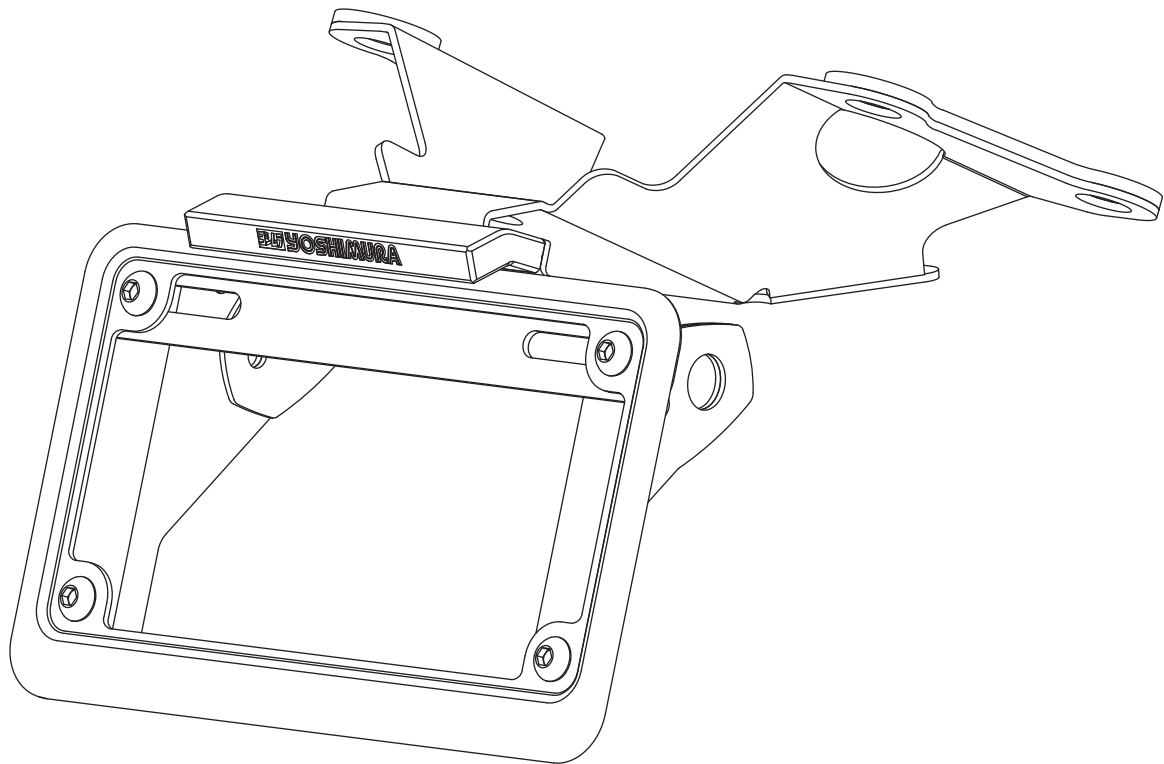

THIS PRODUCT IS NOT DOT APPROVED.

Yoshimura R&D of America, Inc. is not liable or responsible for any resulting event caused by the installation of this product. Check with local laws and regulations for compliance prior to installation and use. This product is not intended for use on public highways.



Assembly Diagram

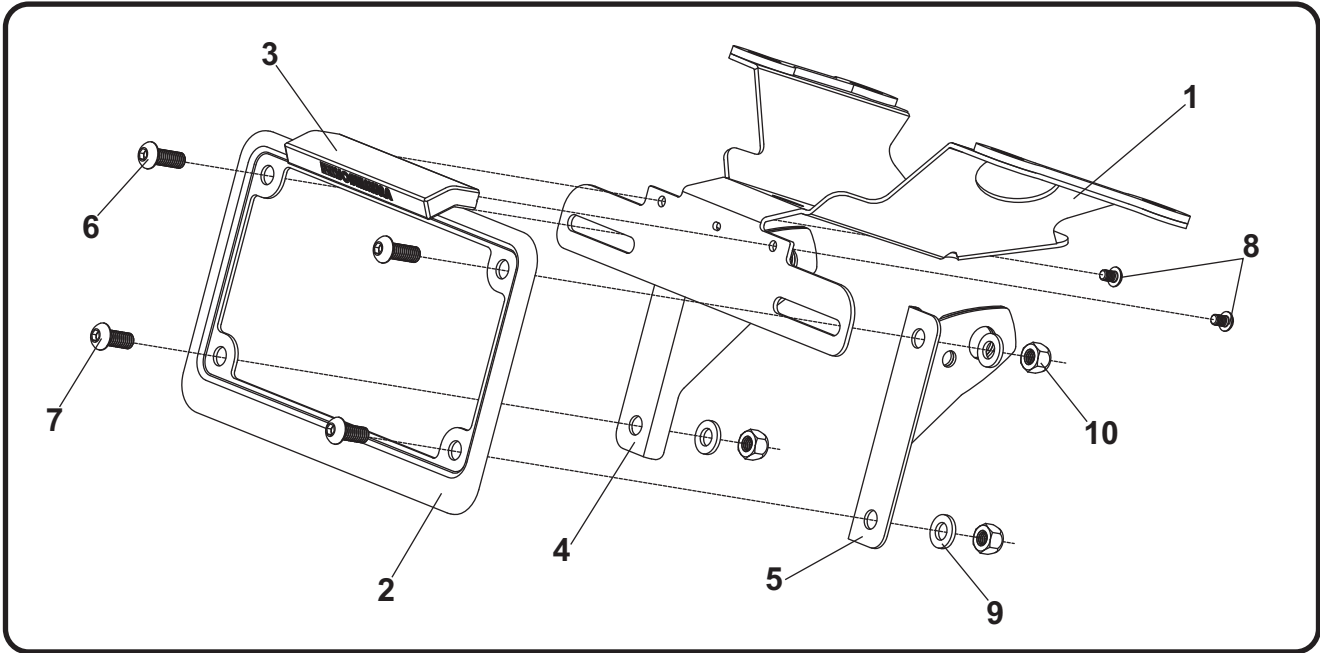

No.	Item	Description	Qty.
1	11182-FEBKT	Fender Eliminator Bracket	1
2	070BG-LPF	License Plate Frame	1
3	070BG-LH-K	Yoshimura License Plate Light	1
4	11182-TSB-L	Left Turn Signal Bracket	1
5	11182-TSB-R	Right Turn Signal Bracket	1
6	M6X16BHS	6mm x 16mm Button Head Screw	2
7	M6X14BHS	6mm x 14mm Button Head Screw	2
8	M4X6BHS	4mm x 6mm Button Head Screw	2
9	6MMWASHER	6mm Flat Washer	4
10	6MMLN	6mm Nylon Lock Nut	4
**	BN-SSS-22-18	Butt Connectors	2
**	ZT-300	Cable Ties	3
**	17029	Yoshimura Sticker Sheet	1
Optional Parts			
***	070BGUNVTBKT	Universal Turn Signal Bracket Kit	

** Not shown on diagram.

*** The Yoshimura Universal Turn Signal Bracket Kit is to be used with aftermarket stud-mounted turn signals and is sold separately.

Removal

1. Remove the black plastic left and right frame covers with the "1000" emblem.
2. Remove rider and passenger seat.
3. Remove left, right, and center rear seat cover cowling.
4. Locate and disconnect left and right turn signal connectors and license plate light connector.
5. While securely supporting the stock fender assembly, remove the (4) bolts securing fender assembly to chassis.
6. Carefully remove the stock fender assembly making sure not to damage turn signal and license plate light connectors.
7. Disassemble and remove left and right turn signals from the stock fender assembly.
8. Cut the stock license plate light connector from the stock fender assembly. Be sure to cut at least a 6" section of wire from the connector.

Installation

1. Install stock turn signals onto (No. 4,5) *11182-TSB-L/R*, left and right turn signal brackets using the stock hardware.
2. Install (No. 2) *070BG-LH-K*, Yoshimura license plate light onto (No. 1) *11182-FEBKT*, fender eliminator bracket using (No. 8) *M4X6BHS*, 4mm button head screws provided in the kit.

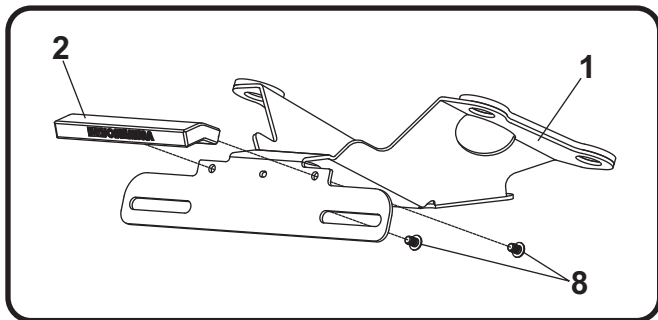

3. Assemble and install (No. 3) *070BG-LPF*, license plate frame and (No. 4,5) *11182-TSB-L/R*, left and right turn signal brackets onto (No. 1) *11182-FEBKT*, fender eliminator bracket as shown.

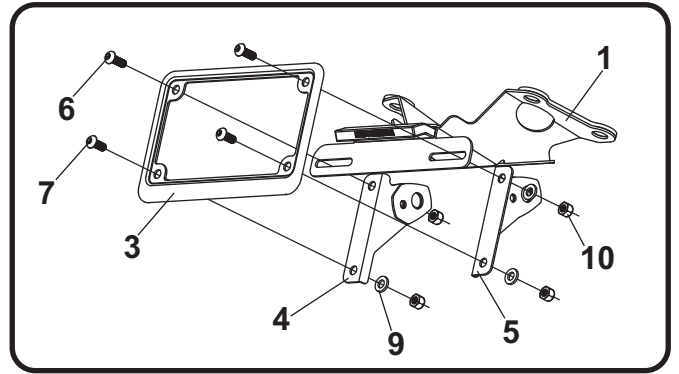

4. Using the *BN-SSS-22-18* butt connectors provided in the kit, connect the Yoshimura license plate light wires to the stock license plate light wires as follows:

Black -to- Black
White -to- Red
5. Route license plate light wire and turn signal wires through the hole in bracket and through lower undertail as shown below. Secure (No. 1) *11182-FEBKT*, to chassis using the (4) stock fender mounting bolts.

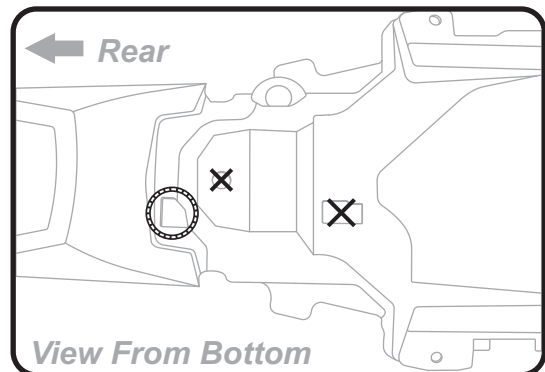

6. Re-connect the stock license plate light and turn signal connectors. Route wires in stock location and secure using supplied cable ties.
7. Re-install left, right, and center rear seat cover cowling using the opposite steps of removal.
8. Re-install passenger and rider seat.
9. Re-install left and right frame covers with the "1000" emblem using the opposite steps of removal.
10. Check for proper function of license plate light and turn signals and that all brackets and components are secure prior to riding.