

SECTION A-A
▲ FRONT ▲

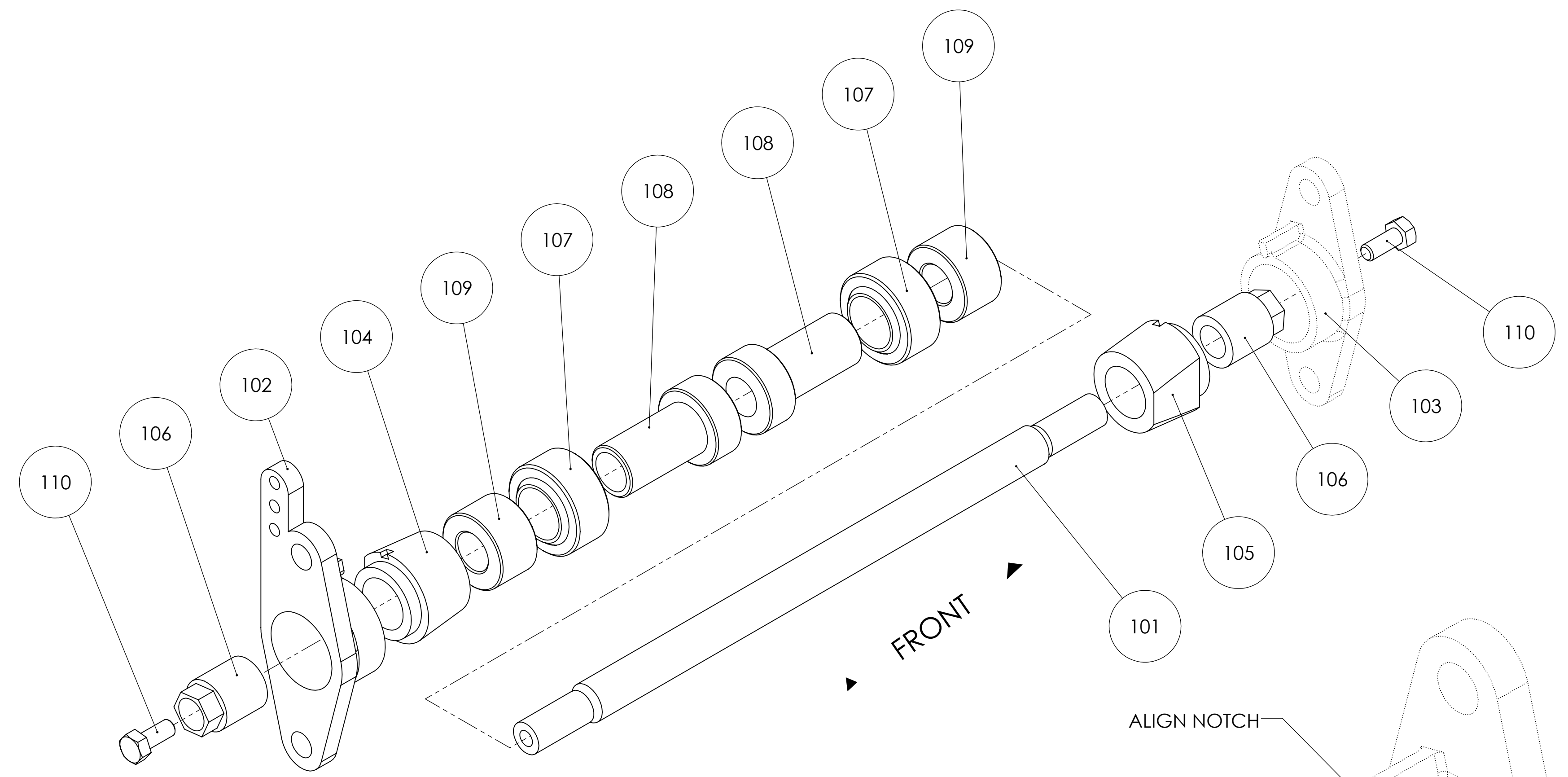

ALIGN NOTCH

DETAIL A
SCALE 4 : 3

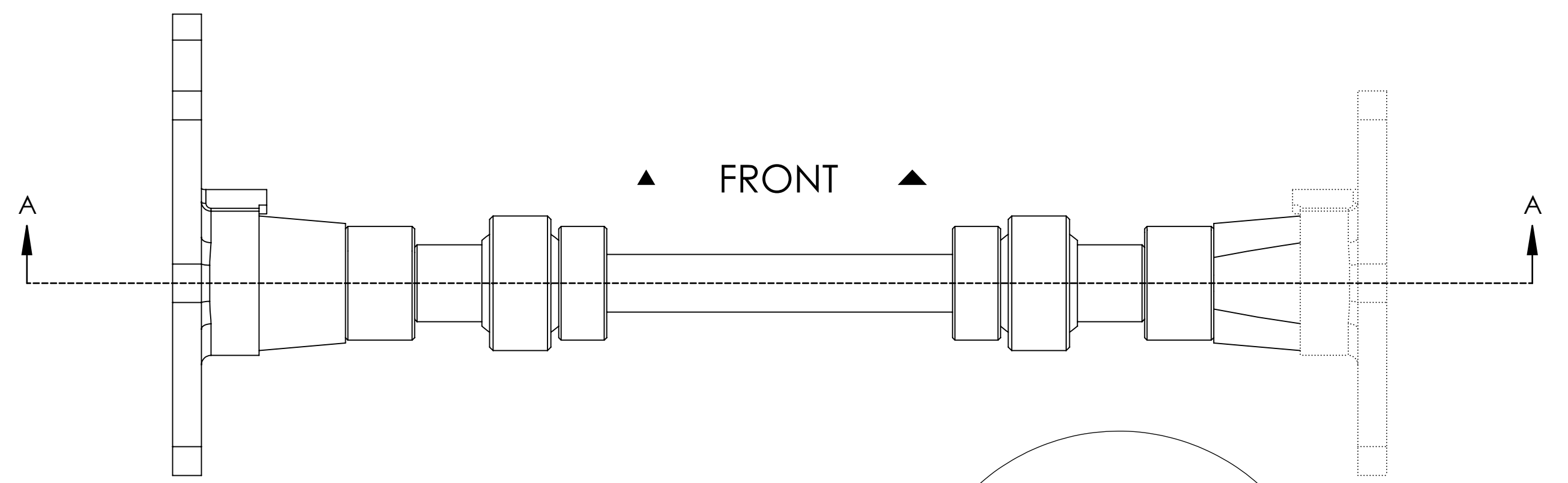
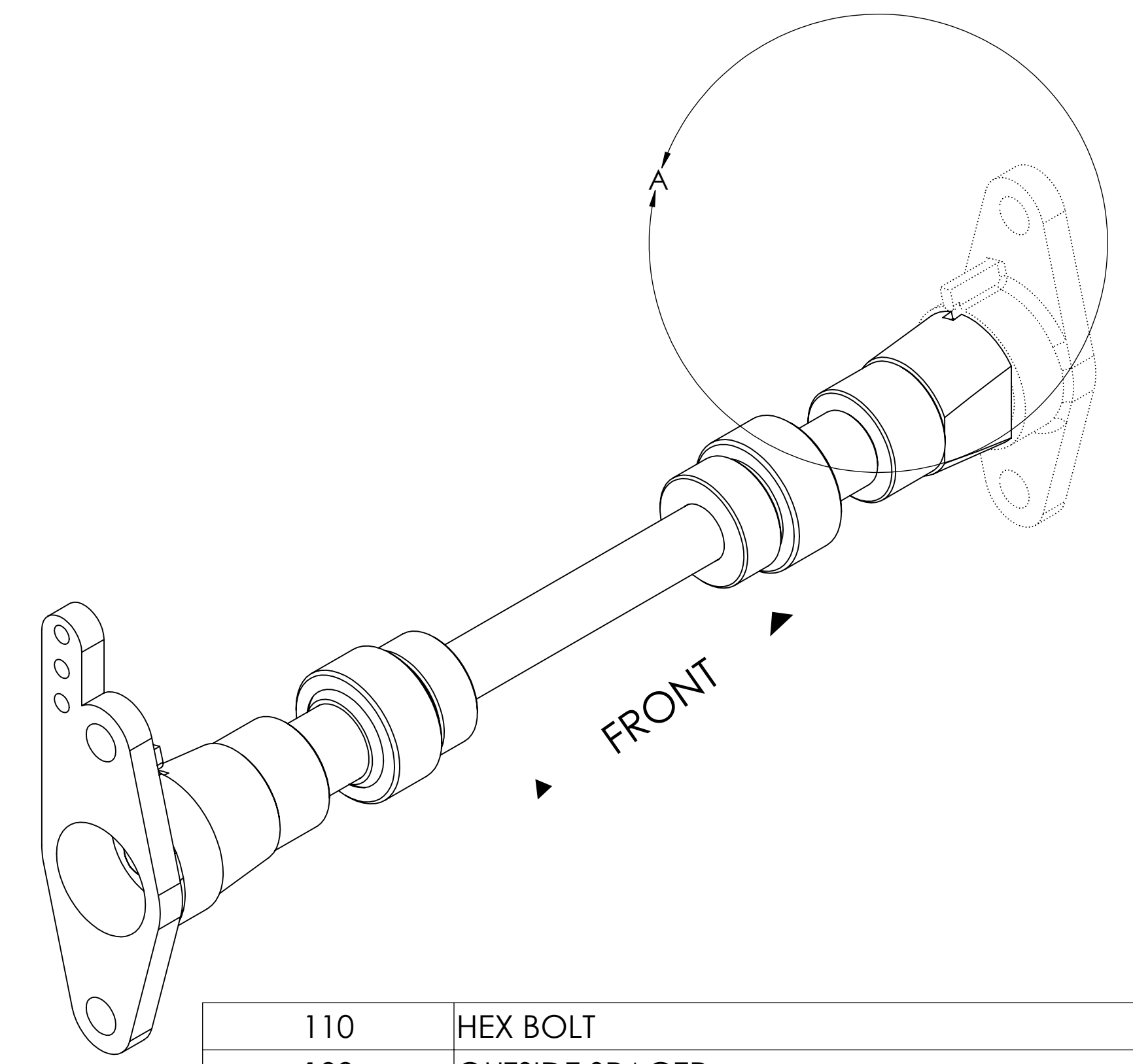

ITEM NO.	DESCRIPTION	QTY.
110	HEX BOLT	2
109	OUTSIDE SPACER	2
108	INSIDE SPACER	2
107	SPHERICAL BEARING 1.00 ID 1.75 OD	2
106	LOCKNUT	2
105	RIGHT BUSHING	1
104	LEFT BUSHING	1
103	RIGHT END CAP	1
102	LEFT END CAP	1
101	PIVOT SHAFT	1

TOLERANCE UNLESS SPECIFIED
ANGLES
 X.X ± 1/2°
 X ± 1°
DIMENSION
 X.XXXX ± .0005 IN.
 X.XXX ± .005 IN.
 X.XX ± .010 IN.
 X.X ± .030 IN.
 CENT ± .001 IN.
NOTE:
 • AXIAL HOLES & DIAMETERS CONCENTRIC TO ±.001
 • DEBURR ALL HOLES & SHARP EDGES .015 MAX
 • PART TO BE FREE OF LUBRICANTS, OILS AND OTHER CONTAMINANTS

NAME: AMK
 DATE: 3/10/2017
 SCALE: 2:3
 SHEET SIZE: D

Brock's PERFORMANCE 4064 E. PATTERSON RD. BEAVERCREEK, OH 45430 (937) 912-0054

PART DESC. **PIVOT BUSHING STACKUP**
 BIKE DESC. **HARLEY-DAVIDSON BAGGER**
 MAT'L _____
 FINISH _____
 SHEET 1 OF 1
 ASC NO. **996902**
 DRW. NO. _____

REV: A

LAST SAVED: Monday, September 30, 2019 11:29:29 AM