

**BST.**



TECHNICAL DOCUMENT

# **STAR TEK WHEEL RANGE**

**COMPILED BY** / D.D. Erasmus / 09 July 2024

**APPROVED BY** / R. Blatch / 09 July 2024





# **CONTENTS**

<b>1. PURPOSE</b>	<b>3</b>
<b>2. BLACKSTONE TEK BACKGROUND</b>	<b>3</b>
<b>3. THE STAR TEK RANGE</b>	<b>4</b>
<b>4. WHEEL CHARACTERISATION</b>	<b>5</b>
4.1 BENDING STIFFNESS MEASUREMENT	5
<b>5. WHEEL REQUIREMENTS</b>	<b>6</b>
5.1 ROTATION BENDING FATIGUE TEST	6
5.2 ALTERNATING TORSION FATIGUE TEST	7
5.3 RADIAL FATIGUE TEST	7
5.4 RADIAL IMPACT TEST	8
<b>6. STAR TEK WHEEL TYPES AND CHARACTERISTICS</b>	<b>9</b>
<b>7. STAR TEK TUV TESTING</b>	<b>9</b>
<b>8. STAR TEK JASO TESTING</b>	<b>10</b>



## 1. PURPOSE

The purpose of this document is to report the proposed technical requirements for carbon fibre monocoque. The document then goes further to report the technical data for Blackstone Tek's (BST) Star Tek wheels.

## 2. BLACKSTONE TEK BACKGROUND

Blackstone Tek (BST) is the internationally recognized leader in the design and manufacture of carbon composite wheels and structural parts for the motorcycle and automotive industry. With 23 years' experience and over 30 000 motorcycle wheels on the roads today, BST is uniquely positioned to develop, manufacture, and supply safe and reliable carbon composite wheels.

All wheels produced by BST are manufactured using Carbon Fibre which is pre-impregnated with an epoxy resin. Each wheel is made up of a combination of 4 variations in weave and modulus of fibre. These materials are accurately and precisely hand placed in the desired position and orientation to ensure an optimal structure.

Following the layup of the fibre plies, the wheels are cured in a pressure and temperature-controlled process. This ensures the consolidation of all the layers, resulting in a strong and rigid monocoque structure. These wheels are then inspected by a full CT Scan and geometrically scrutinized to ensure the absence of any structural defects which would jeopardize the structural integrity of the wheel.

Wheels produced by BST have been documented to provide the following benefits:

- ✓ Lower Rotational Inertia
- ✓ Quicker Acceleration
- ✓ Later Braking
- ✓ Improved Handling
- ✓ Higher Stiffness
- ✓ Improved Fuel Efficiency
- ✓ Composite resilience offering long service life.

BST is a supplier to many OEM manufacturers and BST wheels are produced in accordance with the ISO9001:2015 standard – **our certificate can be found here**. BST is audited and certified by TÜV Rheinland, in accordance with ISO9001:2015 standard, the manufacturing process retains full material traceability throughout. All details pertaining to manufacture, including all processes, are recorded and can be made available.



### 3. THE STAR TEK RANGE

This new range of wheels was developed to meet aftermarket motorcycle wheel demands of Blackstone Tek. This range includes a normal-duty front wheel (FW), a conventional rear wheel (CRW) and an offset rear wheel (ORW) specially designed for sport motorcycles.

Each wheel has a unique serial number. To ensure that every wheel meets the stringent quality requirements, a 100% inspection rate will be implemented along the Star Tek range. The following inspections are performed on every wheel:

- Visual cosmetic inspection
- Dimensional and ETRTO profile inspection

The wheel designs are characterised to ensure that the performance requirements set in the initial phase are met. These include weight, bending stiffness, and rotational inertia.

The Star Tek wheel designs are characterised to ensure that the performance requirements set in the initial phase are met. These include weight and bending stiffness.

Star Tek wheels are designed to meet both JWL and TUV test standards. The maximum static load rating on the front wheel is 155 kg and the offset as well as conventional rear wheels are 280 kg. These values may be seen in Table 1. The execution of the tests and the required loads are described section 5 & 6. The test results of the 7055, 8039 and 9025 wheel types are included in Section 7 & 8..

**Table 1 Allowable GVWR**

7055 (Star Tek 17 x 3.5 FW) Static Load Rating	155 kg
8039 (Star Tek 17 x 6.0 CRW) Static Load Rating	280 kg
9025 (Star Tek 17 x 6.0 ORW) Static Load Rating	280 kg



## 4. WHEEL CHARACTERISATION

Through the characterisation process the design's suitability and relevant inspection criteria can be determined. The properties of primary concern are the mass at various production points and the rotational inertia of the wheel.

### 4.1 BENDING STIFFNESS MEASUREMENT

A high bending stiffness generally improves the handling characteristics of the vehicle as it governs the wheel's deflection during cornering manoeuvres. However, a wheel that is too stiff results in excessive deformation of the tyre, which leads to overheating and premature tyre wear.

The edge of the wheel is mounted onto a rigid plate. An adapter is fixed to the wheel's hub. The nuts are torqued to the manufacturer's specification. The load arm is then connected to the adapter. The bending stiffness is measured in line with a spoke.

The stiffness is calculated from deflection measurements at a known load ( $F$ ), as seen in Figure 2. The load is then divided into horizontal and vertical components by using angle  $\theta$ . The deflection of this arm ( $X_B$ ) is measured at a distance of  $H_B$  from the hub face. The deflection of the hub ( $X_A$ ) is measured at a distance of  $H_A$  from the hub face. From these measurements the number of degrees that the hub's face deflects ( $\beta$ ) can be calculated. The bending stiffness is then calculated by dividing the moment ( $M_B$ ) by the angle deflected ( $\beta$ ).

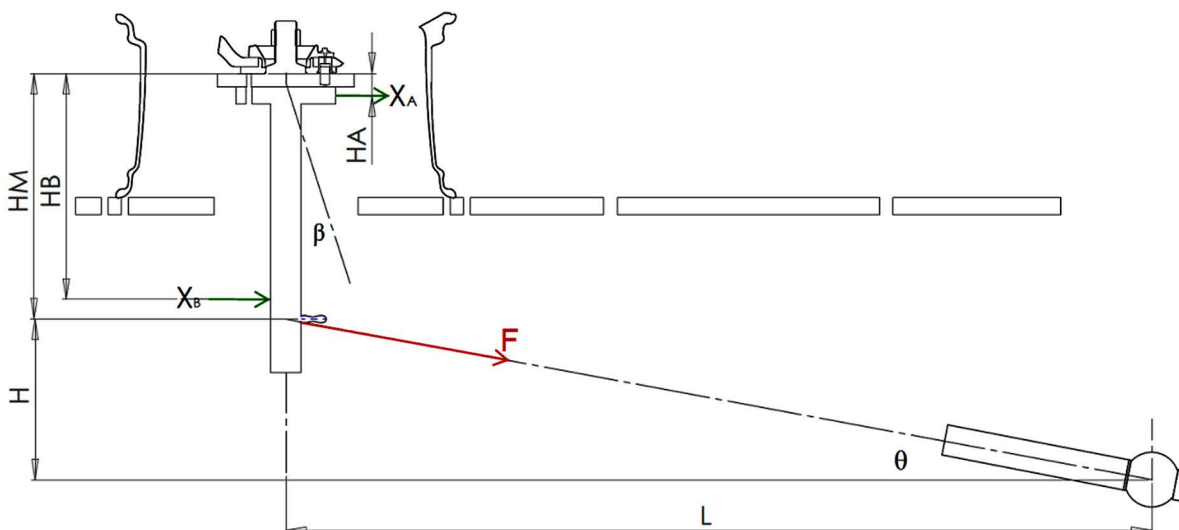

**Fig. 01** Bending Stiffness Experiment



## 5. WHEEL REQUIREMENTS

For motorcycle applications the TUV No. 287 StVZO 1998 & JASO T203-85 standards specify the loads required for the wheel design to pass. The loads specified are used as a baseline to decide on the design load. These loads depend on the static load rating required as well as the size of the wheel.

### 5.1 ROTATION BENDING FATIGUE TEST

In the Cornering fatigue test, the side forces acting on the wheel during a cornering manoeuvre are simulated. This test was done in accordance with the TUV No. 287 StVZO 1998 & JASO T203-85 requirements. This standard specifies that the wheel design will be tested at the calculated moment ( $M_b$ ) for 1 000 000 cycles for TUV and 100 000 cycle for JASO.

The moment is calculated with Equation 1 below:

$$\text{Eq. (1)} \quad M_B = f * F_R (R_{dyn} + e + l)$$

Where:

$M_B$  = Reference moment for load levels [Nm]

$f$  = Wheel load increase factor

$F_R$  = Permissible static vertical wheel load [N]

$R_{dyn}$  = Dynamic tyre radius [m]

$e$  = Offset [m]

$l$  = Half width of tread [m]

The wheel is clamped on the flange of the outer lip. Spacers take the place of the bearings and an axle is fitted to the wheel. The axle is torqued as required by the motorcycle manufacturer.

The load arm is connected to the axle with an eccentric weight. An electric motor spins the eccentric weight. This creates a force  $F$  that is at a known distance away from the hub face. Strain gauges, placed on the load arm, are used to calculate the bending moment on the wheel and count the number cycles. As the frequency of the motor increases, the speed at which the eccentric weight spins at increases. Spinning the weight faster produces a greater force  $F$ , and hence a greater bending moment. The motor frequency, and hence the load, typically changes when the stiffness of the mounts or wheel changes. There are frequency variations in the motor frequency that is caused by the motor controller; however small changes are of little concern. The motor controller outputs the motor frequency against the number of cycles at the end of the test. A significant decrease in motor frequency is indicative of a loss in stiffness.



## 5.2 ALTERNATING TORSION FATIGUE TEST

In the alternating torsion fatigue test, the tangential forces acting on the wheel during braking and accelerating are simulated. This test was done in accordance with the TUV No. 287 StVZO 1998 & JASO T203-85 requirements. The standard specifies that the wheel design will be tested the calculated torsional moment (MT) for 1 000 000 cycles for TUV and 100 000 cycles for JASO.

The torsional moment is calculated with Equation 2 below:

**Eq. (2)**  $M_T = f \times F_R \times R_{dyn}$

Where:

$M_T$  = Alternating torsional moment [Nm]

$f$  = Wheel load increase factor

$F_R$  = Permissible static wheel load [N]

$R_{dyn}$  = Dynamic tyre radius [m]

The wheel is clamped on the outside surface. The electric motor turns an eccentric shaft that creates a sinusoidal variation of the force. The crank arm acts through a linear bearing so that the wheel only sees a horizontal force. This horizontal force is measured by the load cell and creates a moment around the axle.

## 5.3 RADIAL FATIGUE TEST

In the radial fatigue test, the radial forces acting on the wheel in straight ahead driving are simulated, this test was done in accordance with the TUV No. 287 StVZO 1998 & JASO T203-85 requirements. The standard specifies that the wheel must be tested in the straight ahead position with radial load (FP) acting on it for 6000 km for TUV and 500 000 cycles for JASO. The load is calculated by using Equation 3.

The mass of the drop weight is calculated with Equation 3 below:

**Eq. (3)**  $F_p = f F_R$

Where:

$f$  = Wheel load increase factor

$F_r$  = Permissible static wheel load [N]

The wheel is mounted with its axis of rotation parallel to that of a driven drum of at least 1.7 m in diameter. The wheel with the tyre fitted must be held in contact with the drum for the duration of the test at the load specified. The load is applied with a hydraulic ram through a load cell. The fixture is then locked into position with threaded fasteners, thus securing the load.

The wheel must be driven at a speed of between 60-100 km/h. The starting pressure of the tyre is specified as per Table 3 but does not need to be regulated throughout the test.

**Table 2 Required Tyre Inflation Pressures**

Normal Operating Pressure	Tyre Inflation Pressure at Start of Test
Up to 1.6 bar	2.8 bar
Above 1.6 bar	4.5 bar

A pass is considered to be no technical cracks (material separation with a propagation of more than 1 mm).



## 5.4 RADIAL IMPACT TEST

The TUV No. 287 StVZO 1998 and JASO T203-85 standard specifies the load that must be dropped radially onto the wheel. This simulates the wheel striking a road surface defect. The wheel is required to hold some air pressure after impact, such that the motorcycle can be brought to a controlled stop. The load is split into two weights; the auxiliary weight that is fixed and the main weight that is changed as required. These two weights are connected via two springs. The JASO standard specifies that the wheel design will be tested with a drop weight.

The mass of the drop weight is calculated with Equation 3 below:

**Eq. (3)**  $M_1 + M_2 = K \frac{W}{g}$

Where:

$M_1$  = The mass of main striker weight [kg]

$M_2$  = The mass of auxiliary striker weight [kg]

$W$  = Permissible static vertical wheel load [N]

$K$  = Design load coefficient

$g$  = Gravitation acceleration [m/s<sup>2</sup>]

The wheel is fixed radially and fitted with a tubeless tyre of the motorcycle manufacturer's specified size. A pass is considered to be no through-thickness cracks and the wheel must still have a tyre pressure of 1.5 bar after 30 seconds.





## 6. STAR TEK WHEEL TYPES AND CHARACTERISTICS

Below is a summary of the characterisation and test results that the wheel designs have been subjected to.

**Table 3 Wheel Types**

Wheel	Wheel Type	Static Load Rating	Wheel Size
7055	Front	155 kg	FW 17" x 3.5"
8039	Conventional Rear	280 kg	CRW 17" x 6"
9025	Offset Rear	280 kg	ORW 17" x 6"

**Table 4 Wheel Characteristics**

Wheel	Packaged Weight	Bending Stiffness
7055	2.40 kg <sup>1</sup>	1,915 N·m/°
8039	2.75 kg <sup>2</sup>	2,958 N·m/°
9025	2.20 kg	1,626 N·m/°

## 7. STAR TEK TUV TESTING

**Table 5 Cornering Fatigue Test TUV No. 287 StVZO 1998 Standard**

Wheel	Applied Load	Required Load	Cycles	Pass/Fail
7055	431 N·m	431 N·m	1 000 000	Pass
8039	662 N·m	662 N·m	1 000 000	Pass
9025	695 N·m	695 N·m	1 000 000	Pass

**Table 6 Alternating Torsion Fatigue Test TUV No. 287 StVZO 1998 Standard**

Wheel	Applied Load	Required Load	Cycles	Pass/Fail
7055	466 N·m	456 N·m	1 000 000	Pass
8039	1 027 N·m	1 015 N·m	1 000 000	Pass
9025	1 026 N·m	1 015 N·m	1 000 000	Pass

**Table 7 Radial Fatigue Test TUV No. 287 StVZO 1998 Standard**

Wheel	Applied Load	Required Load	Distance	Pass/Fail
7055	349 N·m	349 N·m	6 000 km	Pass
8039	630 N·m	630 N·m	6 000 km	Pass
9025	630 N·m	630 N·m	6 000 km	Pass

<sup>1</sup> Excluding bearings, spacers, and brake carriers.

<sup>2</sup> This is the weight of the wheel assembly only without brake adaptor, bearings, spacers and the sprocket carrier.



**Table 8 Radial Impact Load TUV No. 287 StVZO 1998 Standard**

Wheel	Applied Load	Required Load	Pass/Fail
7055	155 kg	155 kg	Pass
8039	280 kg	280 kg	Pass
9025	280 kg	280 kg	Pass

## 8. STAR TEK JASO TESTING

**Table 9 Cornering Fatigue Test JASO T203-85 Standard**

Wheel	Applied Load	Required Load	Cycles	Pass/Fail
7055	223 N·m	223 N·m	100 000	Pass
8039	452 N·m	452 N·m	100 000	Pass
9025	452 N·m	452 N·m	100 000	Pass

**Table 10 Alternating Torsion Fatigue Test JASO T203-85 Standard**

Wheel	Applied Load	Required Load	Cycles	Pass/Fail
7055	465 N·m	456 N·m	100 000	Pass
8039	939 N·m	923 N·m	100 000	Pass
9025	924 N·m	923 N·m	100 000	Pass

**Table 11 Radial Fatigue Test JASO T203-85 Standard**

Wheel	Applied Load	Required Load	Cycles	Pass/Fail
7055	349 N·m	349 N·m	500 000	Pass
8039	630 N·m	630 N·m	500 000	Pass
9025	630 N·m	630 N·m	500 000	Pass

**Table 12 Radial Impact Load JASO T203-85 Standard**

Wheel	Applied Load	Required Load	Pass/Fail
7055	388 kg	388 kg	Pass
8039	420 kg	420 kg	Pass
9025	420 kg	420 kg	Pass